

STANDARD MODELS

ELEVATOR MODELS

Model 50524

Model 50518

Model 50512

Model 9815

Model 9812

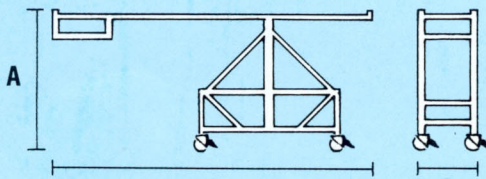
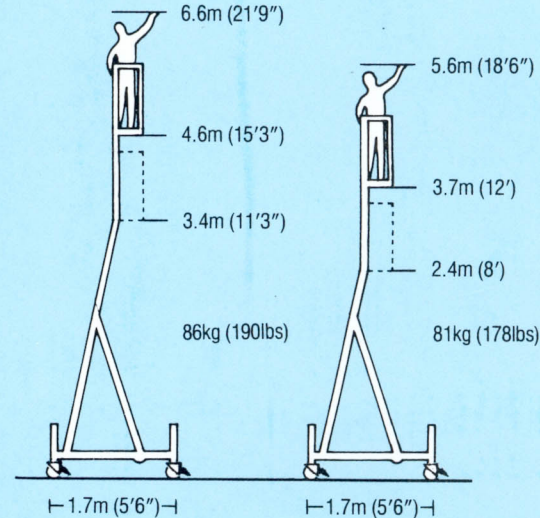
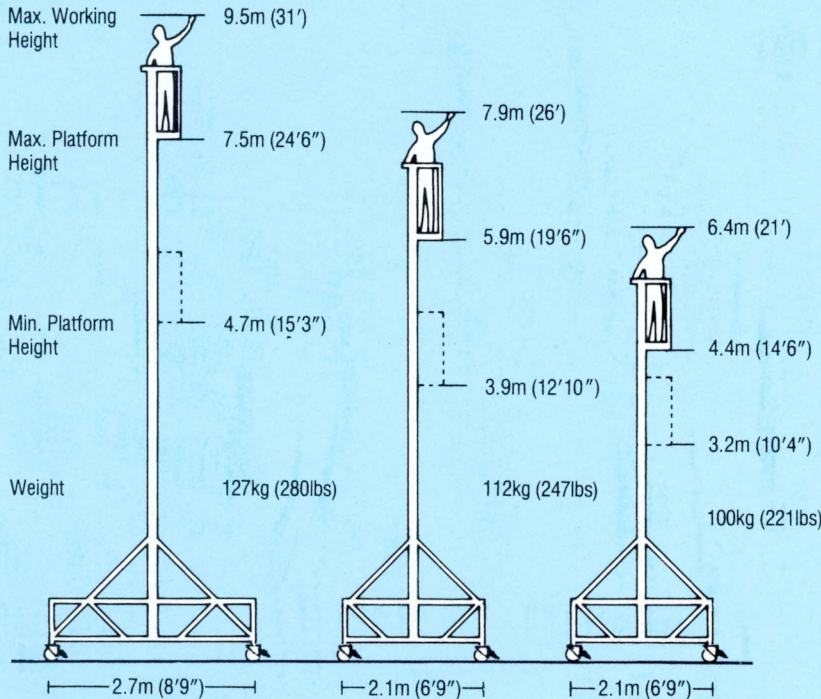

	A	B	C
50524	1.9m (6'4")	5.3m (17'6")	0.74m (2'5")
50518	1.9m (6'4")	4.6m (15')	0.74m (2'5")
50512	1.9m (6'4")	3.8m (12'6")	0.74m (2'5")

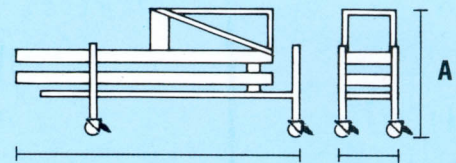

	A	B	C
9815	1.1m (3'6")	2.5m (8'1")	0.74m (2'5")
9812	1.1m (3'6")	2.5m (8'1")	0.74m (2'5")

PLATFORM CAPACITY 115kg (250lbs) ON ALL MODELS.